

Jasper



INFORMAZIONI TECNICHE

Struttura: 1-3-6

Masselli portanti in abete di vari spessori. Fianchi di tamponamento in pannelli di particelle di legno in classe E1, particolari in pannelli di fibra di legno dura o cellulosa.

Struttura rivestita completamente in lastre di poliuretano espanso e Tecnoform.

Molleggio: 1-2

Schienale in pannelli di fibra di legno dura o cellulosa.

Seduta in nastri elastici di fibra propilenica e lattice.

Imbottiture: 5-4

Cuscini schienale in fibra di poliestere sfioccato e piuma d'oca.

Cuscini seduta in poliuretano espanso indeformabile densità 40 kg/m³ rivestiti in vera piuma d'oca.

Rivestimento: 7

In tessuto completamente sfoderabile. In pelle sfoderabili solo cuscini. Non disponibile in similpelle.

Piedini: 8

Piedini in metallo verniciati colore nero (ME09) o testa di moro (ME03).

Dimensioni:

Altezza seduta da terra cm. 45

Profondità seduta cm. 63

Altezza da terra struttura retro schiena cm. 67

Altezza piedino cm. 15

TECHNICAL INFORMATION

Structure: 1-3-6

Supporting structure in pinewood of various thicknesses. Remaining parts in Class E1 wood particleboard panels, details in hard or cellulose wood-based panels.

Structure completely covered with foam and Tecnoform.

Springing: 1-2

The back is made of hard or cellulose wood fibre panels.

The seat is supported by propylene and latex elastic belts.

Cushions Padding: 5-4

Back cushions in frayed polyester fibre and down.

Seat cushions made of non-deformable polyurethane foam density 40 kg/cbm, down covered.

Cover: 7

In the fabric version the cover is completely removable. In leather only cushions' cover is removable. In artificial leather not available.

Feet: 8

Metal feet in black laquered colour (ME09) or dark brown (ME03)

Dimensions:

Seat height from ground cm. 45

Seat depth cm. 63

Back structure height cm. 67

Feet height cm. 15

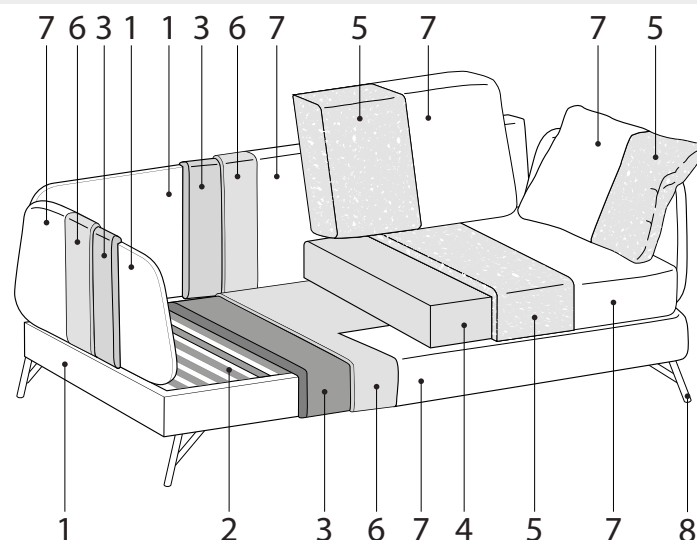

Jasper mix



INFORMAZIONI TECNICHE

Struttura: 1-3-6

Masselli portanti in abete di vari spessori. Fianchi di tamponamento in pannelli di particelle di legno in classe E1, particolari in pannelli di fibra di legno dura o cellulosa.

Struttura rivestita completamente in lastre di poliuretano espanso e Tecnoform.

Molleggio: 1-2

Schienale in pannelli di fibra di legno dura o cellulosa.

Seduta in nastri elastici di fibra propilenica e lattice.

Imbottiture: 5-4

Cuscini schienale in fibra di poliestere sfioccato e piuma d'oca.

Cuscini seduta in poliuretano espanso indeformabile densità 40 kg/m³ rivestiti in vera piuma d'oca.

Rivestimento: 7

Cuscineria in tessuto completamente sfoderabile. Parte esterna della scocca rivestita in pelle sidney, parte interna in tessuto. Scocca non sfoderabile.

Piedini: 8

Piedini in metallo verniciati colore nero (ME09) o testa di moro (ME03).

Dimensioni:

Altezza seduta da terra cm. 45

Profondità seduta cm. 63

Altezza da terra struttura retro schiena cm. 67

Altezza piedino cm. 15

TECHNICAL INFORMATION

Structure: 1-3-6

Supporting structure in pinewood of various thicknesses. Remaining parts in Class E1 wood particleboard panels, details in hard or cellulose wood-based panels.

Structure completely covered with foam and Tecnoform.

Springing: 1-2

The back is made of hard or cellulose wood fibre panels.

The seat is supported by propylene and latex elastic belts.

Cushions Padding: 5-4

Back cushions in frayed polyester fibre and down.

Seat cushions made of non-deformable polyurethane foam density 40 kg/cbm, down covered.

Cover: 7

Cushions' cover in fabric is completely removable. External part of the structure is covered by Sidney leather and internal part in fabric. Structure cover is not removable.

Feet: 8

Metal feet in black laquered colour (ME09) or dark brown (ME03)

Dimensions:

Seat height from ground cm. 45

Seat depth cm. 63

Back structure height cm. 67

Feet height cm. 15

