

Wave, suspension

design Studio Baruffi and De Santi
2009

FOSCARINI



This is not a hanging lamp or floating decorative element, it is not a lighting rail and yet it is all these put together and more. A new idea for illuminating and furnishing spaces, creative raw material that every designer can put together differently and in total freedom. Its sinuous shape gives an idea of flexibility and softness, even though it uses rigid material like extruded aluminium. This adds a strong sculptural and graphic value to an element that is usually seen as purely technical and devoid of personality.

Its ellipsoid outline, as well as contributing this sensation of sinuousness and elegance, contains the light and projects it through a fissure. The luminous effect produced underlines the graphic effect of Wave's shape and can also be used as a light decoration. Thanks to its stylish peculiarity, Wave lends itself to the most innovative uses and the most surprising settings: from the creation of a luminous false ceiling, to the visual characterisation of a wall or enhancing a management area in an office.

Wave, suspension technical info

FOSCARINI

Description

Suspension lamp with indirect up light. Liquid coated cold curved extruded aluminium diffuser. Two stainless steel suspension cables with glossy steel mechanical ceiling attachments and transparent electrical cable. Ceiling rose with galvanised metal bracket and glossy chromed batch-dyed ABS cover.

Materials: Lacquered aluminium

Colours: white, aluminium

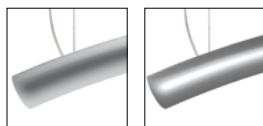

Weight

net kg: 6,00
gross kg: 9,00

Packing

vol.m³: 0,225
n.bboxes: 1

Bulbs

– halogen energy saver 3x80W R7s (78 mm)



Certifications

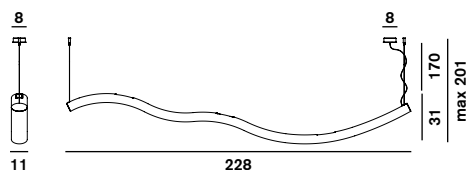

Brightness

direct up light



[2D/3D drawings](#)
[photometric info](#)
[assembly instructions](#)

area download

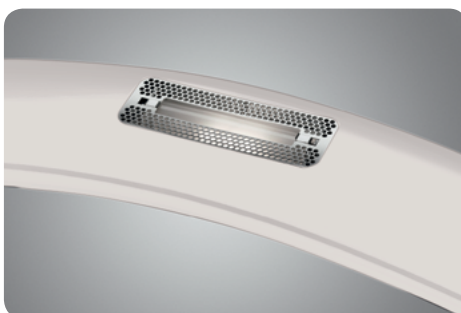

Wave, suspension designer

FOSCARINI

Studio Baruffi and De Santi

Founded in the early 1970s by Maurizio Baruffi and Roberto De Santi, the studio offers consultancy and design for architecture, store, office and showroom furnishings, industrial design and visual design. An important part of its activity is also the restoration and renovation of historic buildings and those of artistic value. The studio works in partnership with industry to provide architectural design services, image coordination, product services and trade fair

presentation. It is a part of modern cultural life and focuses a great deal of attention on the evolution of theories of the present.

Go to concept site for Wave:
www.foscarini.com/wave

